

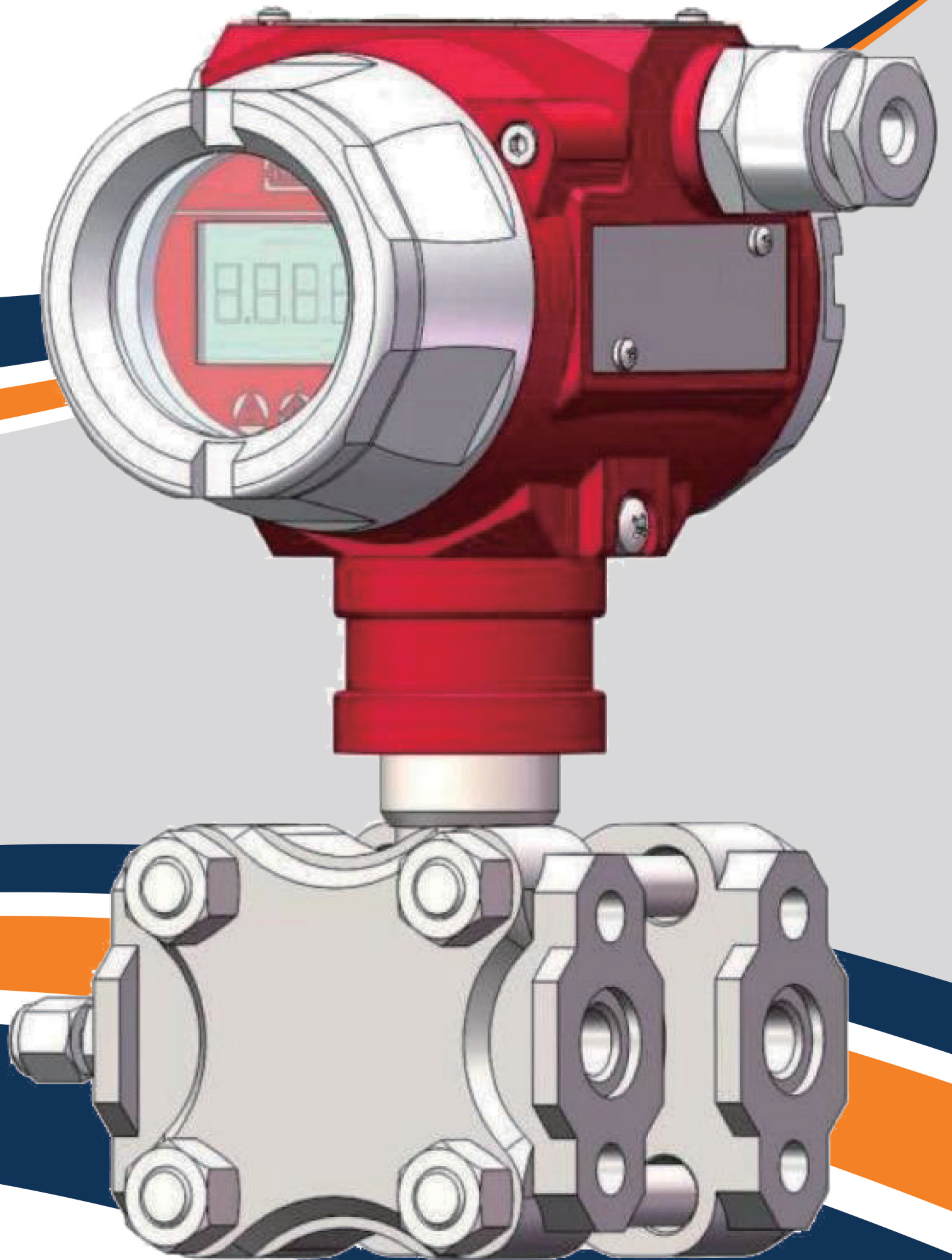

RAYA ENERGY ENGINEERING AND INSTRUMENTATION

C O M P A N Y



Differential Pressure Transmitter

Product Overview

The **REEICO** pressure transmitter, equipped with a cutting-edge mono silicon sensor, is designed for precision in process and environmental applications. It ensures continuous and accurate measurement of pressure differences in liquids, vapors, and gases. Engineered with a robust ex-proof construction, this transmitter is ideal for use in hazardous (EX) areas, offering reliability and safety. With an IP67 rating, it provides exceptional protection against dust and water ingress, ensuring durability in challenging environments.

Key Features

- **Advanced Piezo Technology:** Provides accurate and reliable actuation with minimal wear and improved resistance to vibration.
- **Protection Rating:** IP67, ensuring robust protection against dust and water.
- **Certification:** EX db II C T6 Gb, suitable for hazardous environments.

Wetted Parts

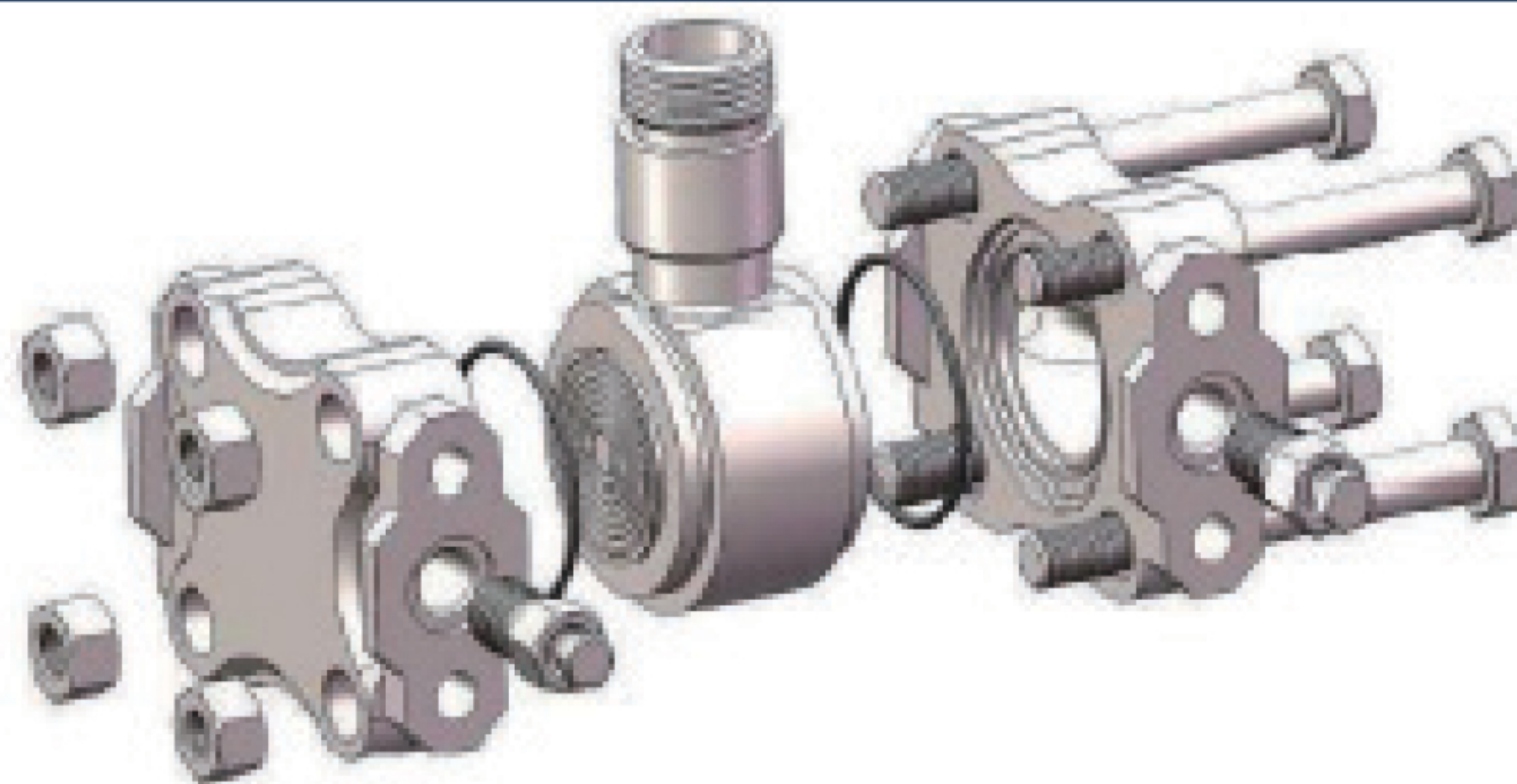

Product Parts

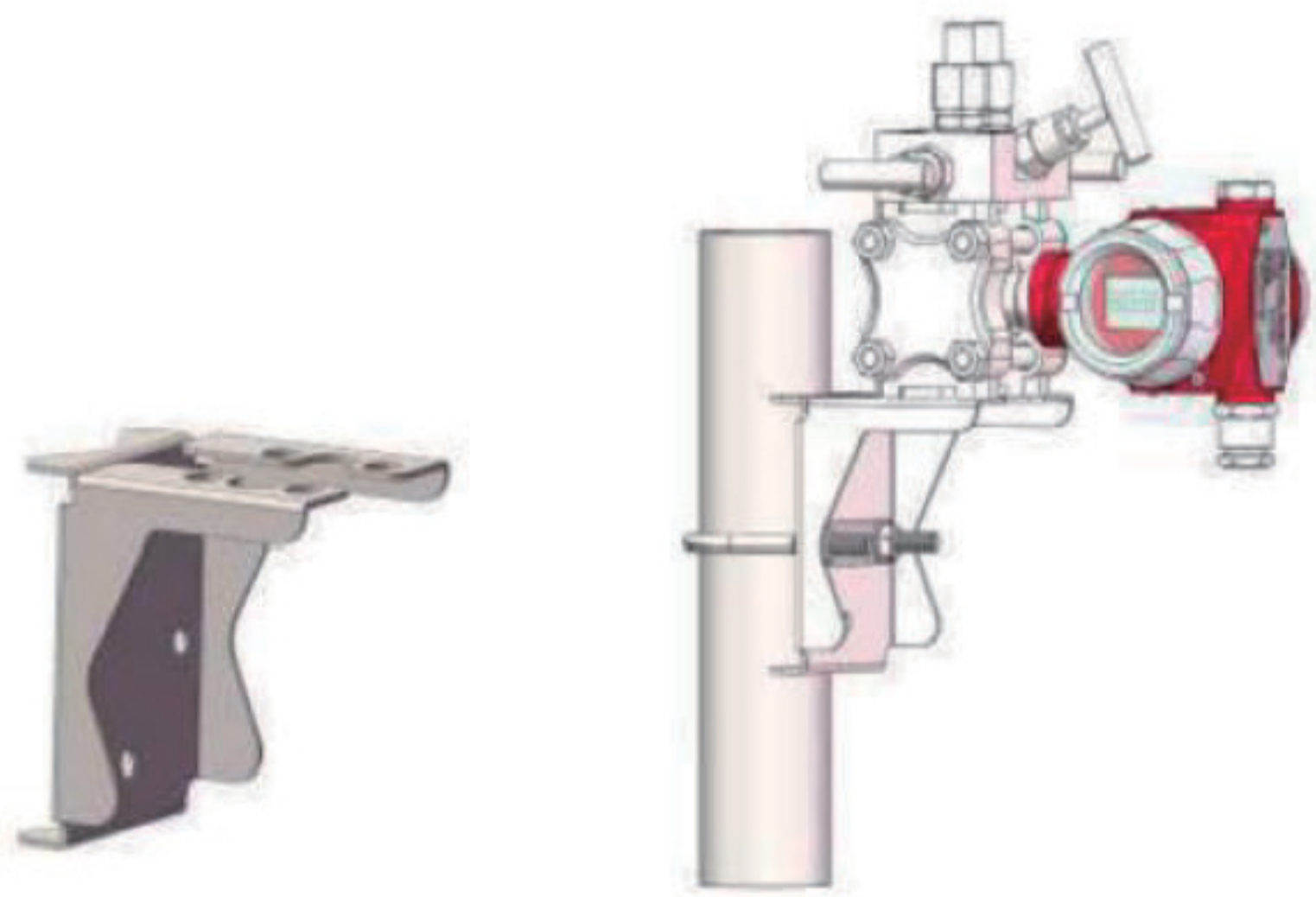
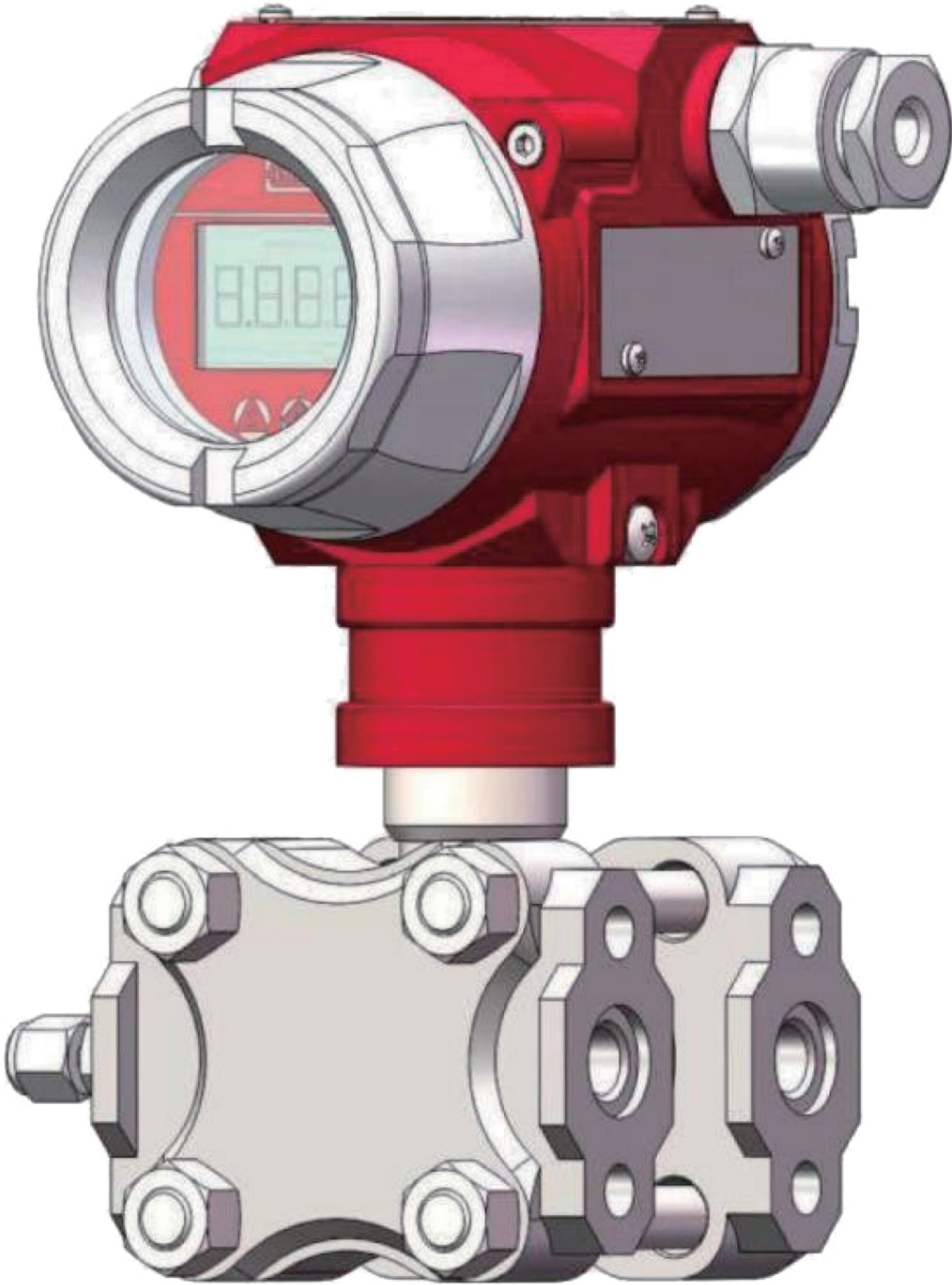

Pipe mounting bent bracket (B1)

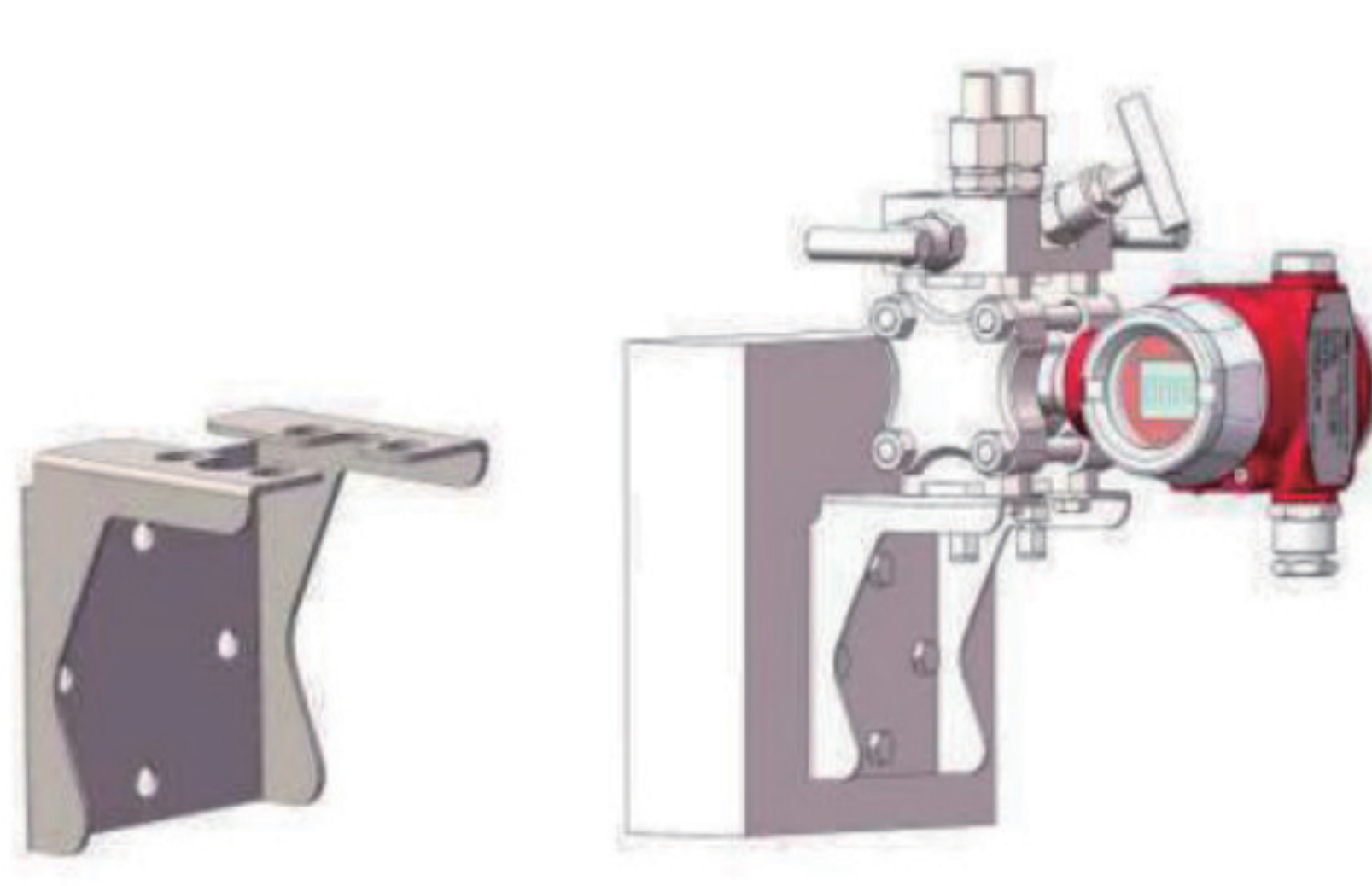
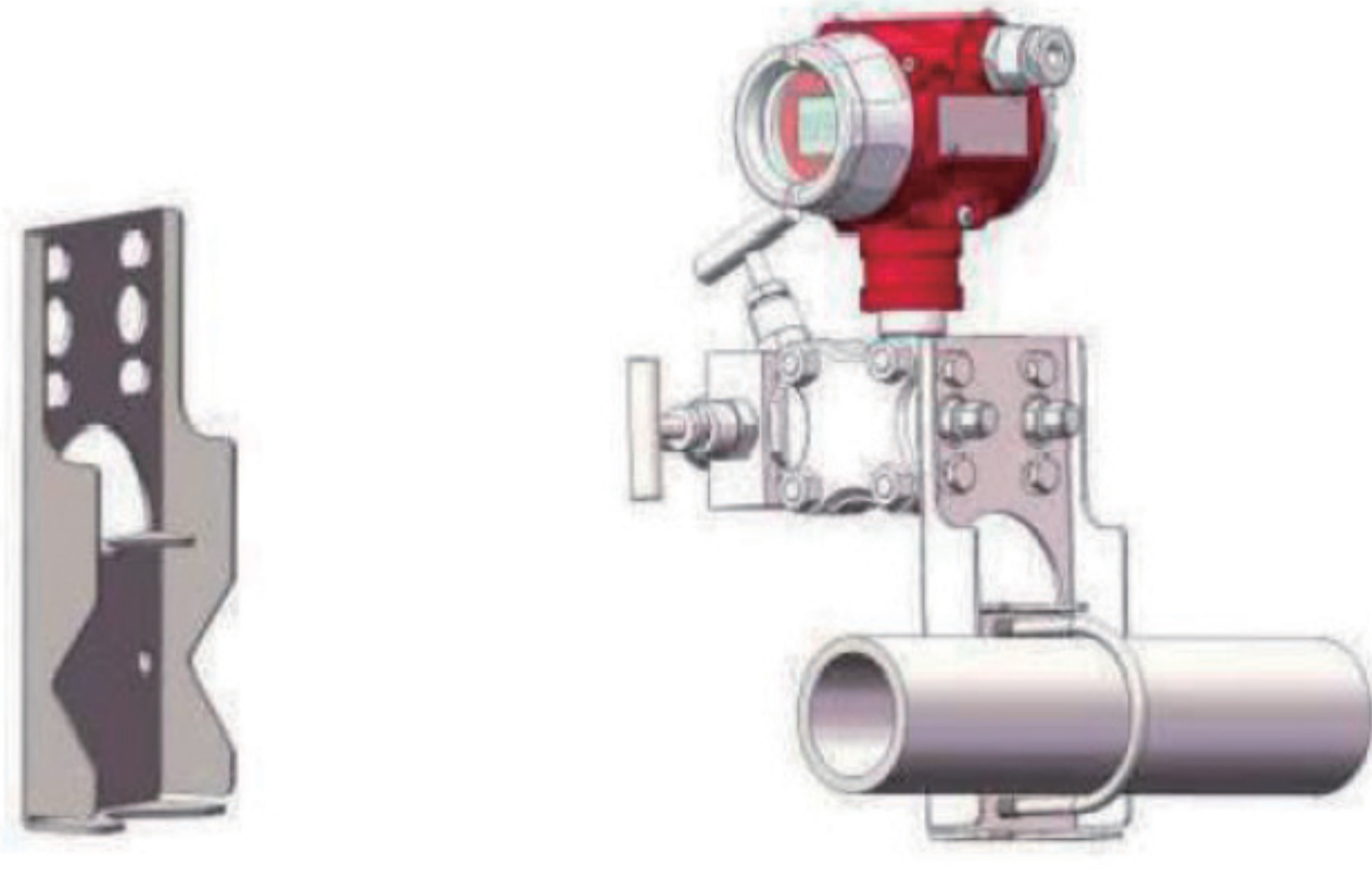

Plate mounting bent bracket (B2)



Pipe mounting flat bracket (B3)



Products introduction

Description

PSRD differential pressure transmitter with monosilicon sensor is typically used in process or environmental applications for continuous measurement of pressure differences in liquids, vapors and gases.

With reliable ex-proof construction and electronics, suitable in EX areas.

Measuring medium

Liquid, gas or steam flow as well as liquid level, density and pressure

Main parameters

Pressure types	Differential pressure
Measuring range	200 Pa to 10M Pa
Output signal	4-20mA, 4-20mA+HART, Modbus-RTU/RS485 customer
Reference accuracy	±0.075% URL, optional ±0.05% URL

Technical specifications

Measuring range and limit

Nominal value	Smallest calibratable span	Lower range limit (LRL)	Upper range limit (URL)	Static pressure limit	High pressure side overload limit	Low pressure side overload limit
6kPa	200Pa	-6kPa	6kPa	25MPa	25MPa	16MPa
40kPa	400Pa	-40kPa	40kPa	40MPa	25MPa	16MPa
250kPa	2.5kPa	-250kPa	250kPa	40MPa	25MPa	16MPa
1MPa	10kPa	-500kPa	1MPa	40MPa	25MPa	16MPa
3MPa	30kPa	-500kPa	3MPa	40MPa	25MPa	16MPa
10MPa	100kPa	-500kPa	10MPa	40MPa	25MPa	16MPa

Adjust requirements: lower range value (LRV) and upper range value (URV) can be adjusted within the scope of the upper and lower range limit, when $|URV| \geq |LRV|$, needs $|URV| \geq$ smallest calibratable span; when $|URV| \leq |LRV|$, needs $|LRV| \geq$ smallest calibratable span

Power supply effects

When power supply voltage is within 10.5/16.5-55VDC, zero and span change should not more than ±0.005%URL/ V

Mounting position effects

Install error less than 400Pa, which can be corrected by PV= 0 reset.

Output signal

Two wire 4-20 mA output with digital communications, linear or square root output programmable, HART protocol is superimposed on the 4-20mA signal.

Power supply

Item	Operating conditions
Standard/flame proof	10.5-55VDC
HART protocol	16.5-55VDC, communication load resistance 250Ω
Modbus-RTU/RS485	5-32VDC
Load resistance	0-2119Ω for operation, 250-600Ω for HART protocol
Transmission distance	<1000 meters
Power consumption	≤500mW@24VDC, 20.8mA

Standard specifications and reference conditions

Test standard : IEC60770 ; Zero based - calibration span, linear output, silicon oil filling, 316 L stainless steel isolation diaphragm

Performance specifications

- The overall performance including but not limited to "Reference accuracy", "Environment temperature effects", "Static pressure effects" and other comprehensive error.
- Typical accuracy: ±0.075 %URL
- Stability : ±0.2 % URL / 5year Startup after power off: ≤6S

Static pressure effects

Effect on zero	±0.15TD % URL/4MPa
Effect on full scale	±0.2% URL/4MPa

Reference accuracy

Including linearity(BFSL), hysteresis and repeatability. calibration temperature: 20°C ± 5°C		
TD≤10 (note1)	+0.075%SPAN(note 2)	Nominal value: 6kPa,40kPa 250kPa,1MPa 3MPa,10MPa
10<TD≤100	+0.0075TD% SPAN	
Square root output accuracy is 1.5 times linear output accuracy		
Note 1: TD is Turn down when $ URV \geq LRV $, $TD=URL/ URV $ when $ URV \leq LRV $, $TD=URL/ LRV $		
Note 2: SPAN= $ URV-LRV $		

Technical specifications

Damping time

- Total damping time constant: equal to the sum of damping time of amplifier and sensor capsule
- Damping time of amplifier : 0-100 S adjustable
- Damping time of sensor capsule (isolation sensor diaphragm and silicon oil filling) ≤0.2 S
- Startup after power off: ≤6S
- Normal service s after data recovery : ≤31 S
- Response time:≤150ms

Ambient temperature effects

Per 10°C change within the limits -20-80 °C	±(0.1+0.015TD)% SPAN
---	----------------------

Vibration effects

According to IEC61298-3,<0.1 % URL

Environment condition

Items	Operational condition
Working temperature	-40-85°C, integrated LCD display:-20-70°C
Storage temperature	-40-110°C, integrated LCD display:-40-85°C
Media temperature	Silicon oil filling: -40-120°C
	Inert oil filling:-40-85°C
Working humidity	5-100%RH@40°C
Protection class	IP66/IP67
Dangerous condition	ATEX Ex db IIC T6 Gb, Ex tb IIC T80°C Db(CML 19ATEX1078X)* Exia IIC T4 Ga(CML 19ATEX1078)*
	CSA Class I, Division 1, Group A, B, C and D T6 Class II, Division 1 Group E, F and G T80 °C Class III (No.: 80020805)*
	IECEX Ex db IIC T6 Gb, Ex tb IIIC T80°C Db (IECEX NEP 18.0008X)* Ex ia IIC T4 Ga (IECEX NEP 18.0008X)*
	IECEX Ex db IIC T6 Gb, Ex tb IIIC T80°C Db (IECEX NEP 18.0008X)* Ex ia IIC T4 Ga (IECEX NEP 18.0008X)*

Environment condition

NO.	Test items	Basic standards	Test conditions	Performance level
1	Radiated interference	EN 55022	30MHz-1000MHz	OK
2	Conducted interference (DC power port)	EN 55022	0.15MHz-30MHz	OK
3	Electrostatic discharge immunity test (ESD)	IEC61000-4-2	4kV(Contact),8kV(Air)	B(Note2)
4	Immunity to radio frequency EM-fields	IEC61000-4-3	10V/m(80MHz-1GHz)	A(Note1)
5	Power frequency magnetic field Immunity test	IEC61000-4-8	30A/m	A(Note1)
6	Electrical fast transient / Burst Immunity test	IEC61000-4-4	2kV(5/50ns,100kHz)	B(Note2)
7	Surge immunity requirements	IEC61000-4-5	1kV(Line to line) 2kV(Line to ground) (1.2us/50us)	B(Note2)
8	Immunity to conducted disturbances induced by radio frequency fields	GB/T 17626.6/IEC61000-4-6	3V(150kHz-80MHz)	A(Note1)

(Note 1)Performance level A: The performance within the limits of normal technical specifications.

(Note 2)Performance level B: Temporary reduction or loss of functionality or performance, it can restore itself. The actual operating conditions, storage and data will not be changed.

Power supply and load requirements

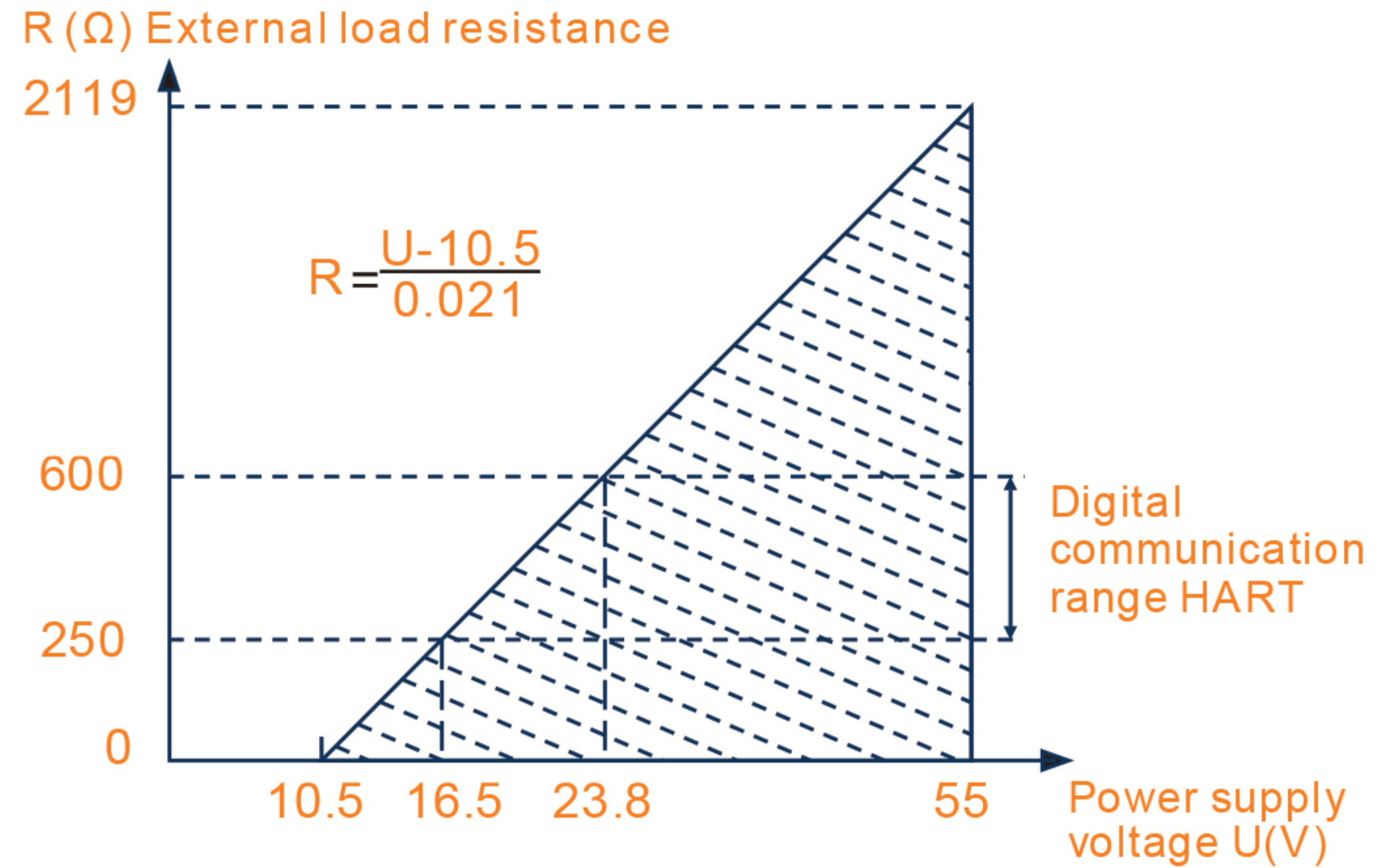

BEYOND RELIABILITY



About us

REEICO is a technology-based company renowned in the MENA region's Oil and Gas industry for our expertise in advanced sensor technologies and instrumentation. Our offerings include a wide range of vibration monitoring sensors such as Eddy current and piezo sensors, gas detection sensors utilizing semiconductor and electrochemical technologies, as well as pressure, temperature, and level transmitters and transducers, valve positioners, among others. Initially focused on manufacturing upstream products and services, we have expanded our capabilities to deliver world-class sensors and instrumentation for both upstream and downstream applications.

At REEICO, we are committed to delivering reliability and confidence to our customers across various industries.

While we may not have been the first, but our goal is to keep continuity on the way to become the best in terms of reliability.